

ZEMPER

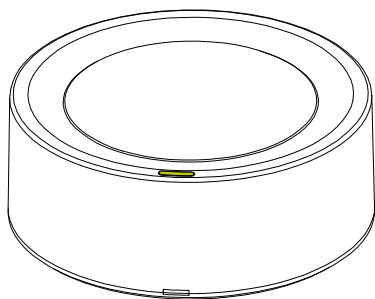

BSZ01
IP-42 IK-04

1 Presentación / Presentation / Présentation /
Presentatie / Presentasjon / Presentazione

Conforme a / According to / Conforme à / I henhold til /
Volgens / Conforme a EN60598-2-22

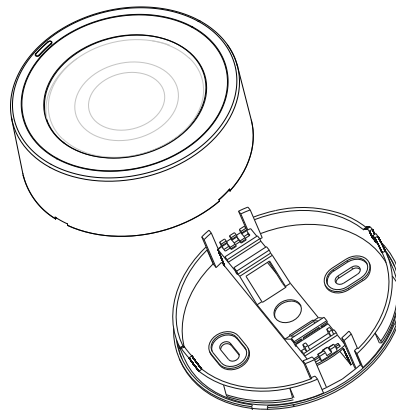

2 Instalación / Installation / Installation / Installatie / Installasjon / Installazione

MODELOS PERMANENTE
MAINTAINED MODELS
MODÈLES PERMANENT
MODELLEN PERMANENTE
VEDLIKEHOLDT MODELLER
MODELLO PERMANENTE

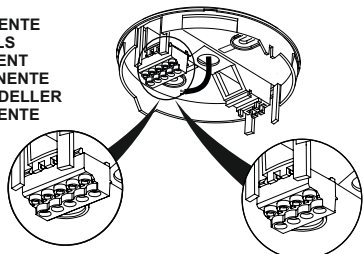

MODELOS NO PERMANENTE
NON MAINTAINED MODELS
MODÈLES NON PERMANENT
MODELLEN NIET PERMANENTE
IKKE VEDLIKEHOLDT MODELLER
MODELLO NON PERMANENTE

MODELOS CON TELEMANDO
REMOTE CONTROL MODELS
MODÈLES AVEC TÉLÉCOMMANDE
MODELLEN MET AFSTANDSBEDIENING
FJERNKONTROLL MODELLER
MODELLO CON TELECOMANDO

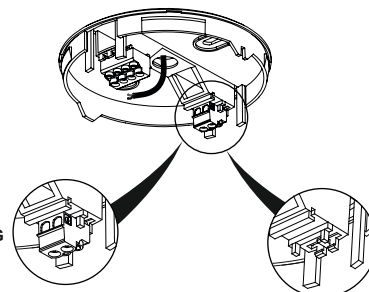

MODELOS SIN TELEMANDO
WITHOUT REMOTE CONTROL MODELS
MODÈLES SANS TÉLÉCOMMANDE
MODELLEN ZONDER AFSTANDSBEDIENING
UTEN FJERNKONTROLL MODELLER
MODELLO SENZA TELECOMANDO

FIJACIÓN EN TECHO
CEILING FIXING
FIXATION AU PLAFOND
PLAFOND BEVESTIGING
TAKFESTING
FISSAGGIO A SOFFITTO

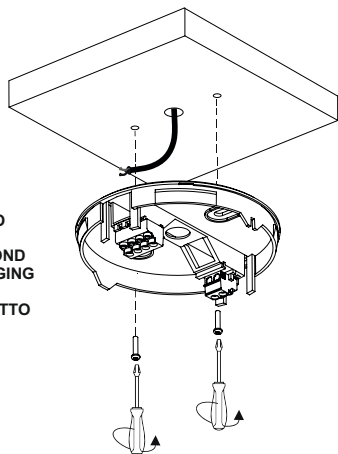

1

FIJACIÓN EN PARED
WALL FIXING
FIXER AU MUR
MUURBEVESTIGING
VEGGFESTE
FISSAGGIO A MURO

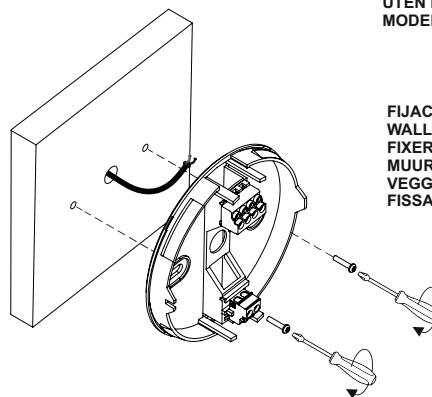

2

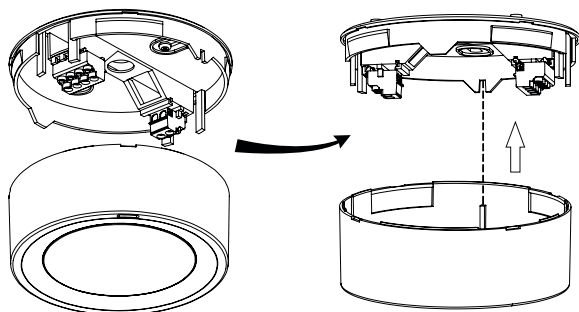

3

LED de carga + Botón de prueba
Charging LED + Test button
LED de charge + Bouton test
Oplaaad-LED + Testknop
Lade LED + Test-knapp
LED di carica + pulsante di test

MODELOS PERMANENTE-NO PERMANENTE
 MAINTAINED-NON MAINTAINED MODELS
 MODÈLES PERMANENT-NON PERMANENT
 MODELLEN PERMANENTE-NIET PERMANENTE
 VEDLIKEHOLDT-IKKE VEDLIKEHOLDT MODELLER
 MODELLO PERMANENTE-NON PERMANENTE

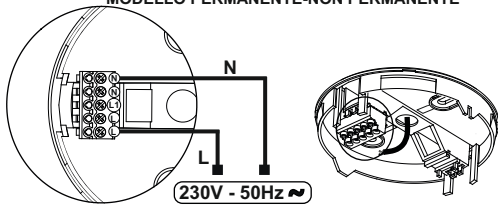

NO PERMANENTE / NON MAINTAINED /
 NON PERMANENT / NIET PERMANENTE /
 IKKE VEDLIKEHOLDT / NON PERMANENTE

ON (permanente) - OFF (no permanente)
 ON (maintained) - OFF (non maintained)
 ON (permanent) - OFF (non permanent)
 AAN (permanent) - UIT (niet permanent)
 PÅ (vedlikeholdt) - AV (ikke vedlikeholdt)
 ON (mantenuto) - OFF (non mantenuto)

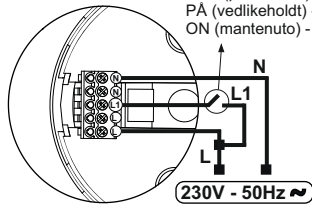

PERMANENTE / MAINTAINED / PERMANENT /
 PERMANENTE / VEDLIKEHOLDT / PERMANENTE

MODELOS NO PERMANENTE
 NON MAINTAINED MODELS
 MODÈLES NON PERMANENT
 MODELLEN NIET PERMANENTE
 IKKE VEDLIKEHOLDT MODELLER
 MODELLO NON PERMANENTE

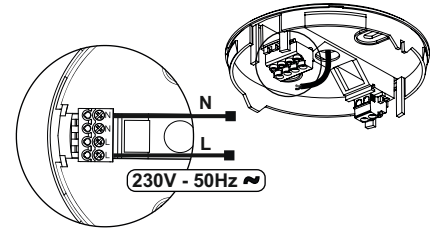

**SISTEMA AUTOTEST CENTRALIZADO SmartZ / SELF-TEST CENTRALIZED SmartZ SYSTEM /
 SYSTÈME AUTOTEST CENTRALISÉ SmartZ / SmartZ GECENTRALISEERD ZELFTEST SYSTEEM /
 SELV TEST SENTRALISERT SmartZ SYSTEM / SISTEMA AUTOTEST CENTRALIZZATO SmartZ**

230V - 50Hz ~

CENTRAL SmartZ
 SmartZ UNIT
 CENTRALE SmartZ
 CENTRAAL SmartZ
 SmartZ SENTRAL
 CENTRALE SmartZ

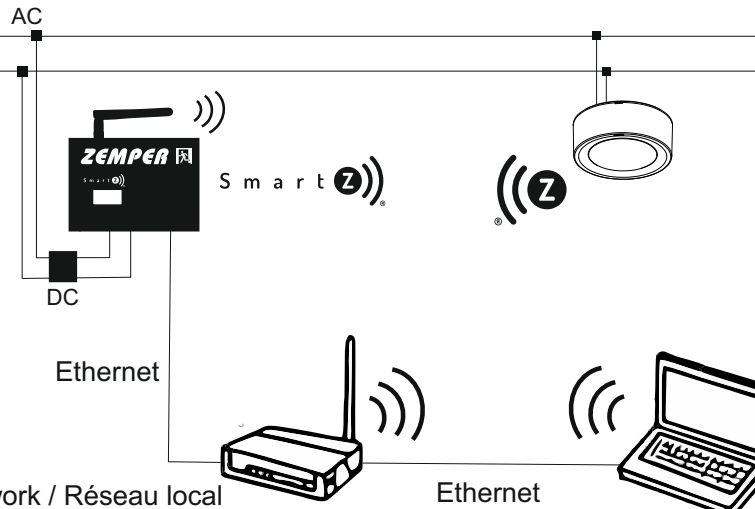

Red Local / Local Network / Réseau local
 Lokaal netwerk / Lokalt nettverk / Rete locale

