

ZWEBDALI

Zemper DALI control panel for DALI emergency lighting systems with Ethernet Interface and integrated Web-server

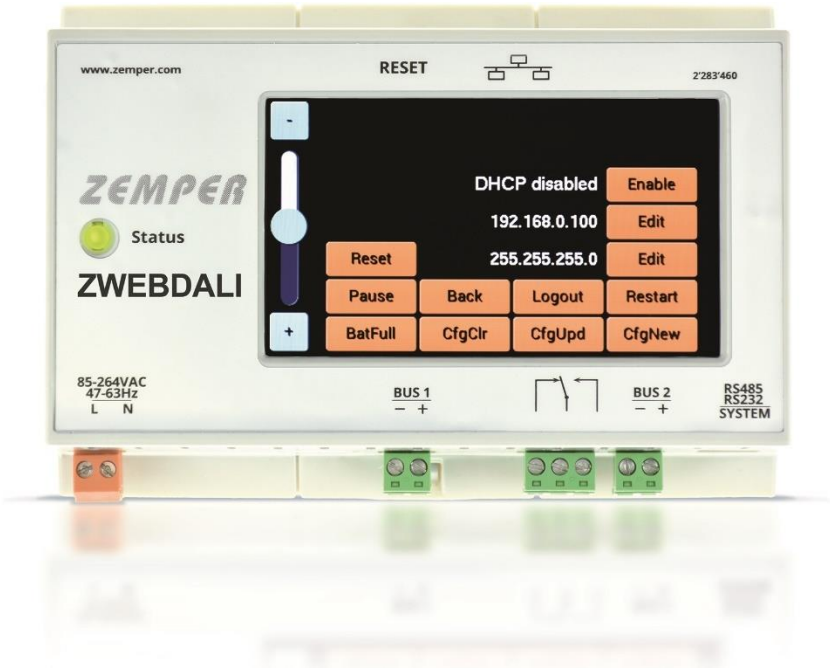

VERSION 1.0

Index content

1	ZWEBDALI system components interconnections.....	4
2	The ZWEBDALI Emergency lighting system and its elements.....	4
3	Installation.....	5
4	Start of the software.....	5
5	Web interface.....	6
5.1	Navigation window	6
5.2	Communication-window.....	7
5.3	Unit Information	7
5.4	Parameters modification	10
5.5	Device list	11
5.6	Existing fault-list.....	12
5.7	Test record	13
5.8	All tests	13
5.9	Administrator Configuration	15
5.10	General Configuration.....	16
5.11	Network/mail Configuration.....	18
5.12	New system configuration.....	19
5.13	Test time configuration.....	20
5.14	Delete emergency lighting units:.....	20
5.15	Special feature – remote control	21
6	FTP Transfer	21
7	Firmware low level monitor	22
7.1	Upgrading the application with AutoUpdate	24
8	Return to factory settings / Restart	24
9	LCD touchscreen operation (optional)	25
9.1	Basic system configuration with LCD interface	26
9.1.1	IP address configuration.....	26
9.1.2	DALI devices configuration.....	26
9.1.3	Other configuration buttons	27
9.2	DALI devices status	27
9.3	DALI device error information	28
9.4	DALI device controls.....	29
9.5	DALI devices fault list	30
9.6	DALI devices tests	30
9.7	Optional information on the main LCD screen	31

10	ZWEBDALI Telnet interface	32
10.1	Telnet commands list	32
10.2	DALI micro controller commands	37
10.3	DALI commands	38
10.4	DALI extended commands.....	40
11	Size and weight	42

Revision history:

1.2, 2018-10-03 – Add LCD and Telnet

1.1, 2018-09-04 – Update pictures, add metal enclosure dimensions

1.0, 2018-08-01 – Convert from MWEB user guide

1 ZWEBDALI system components interconnections

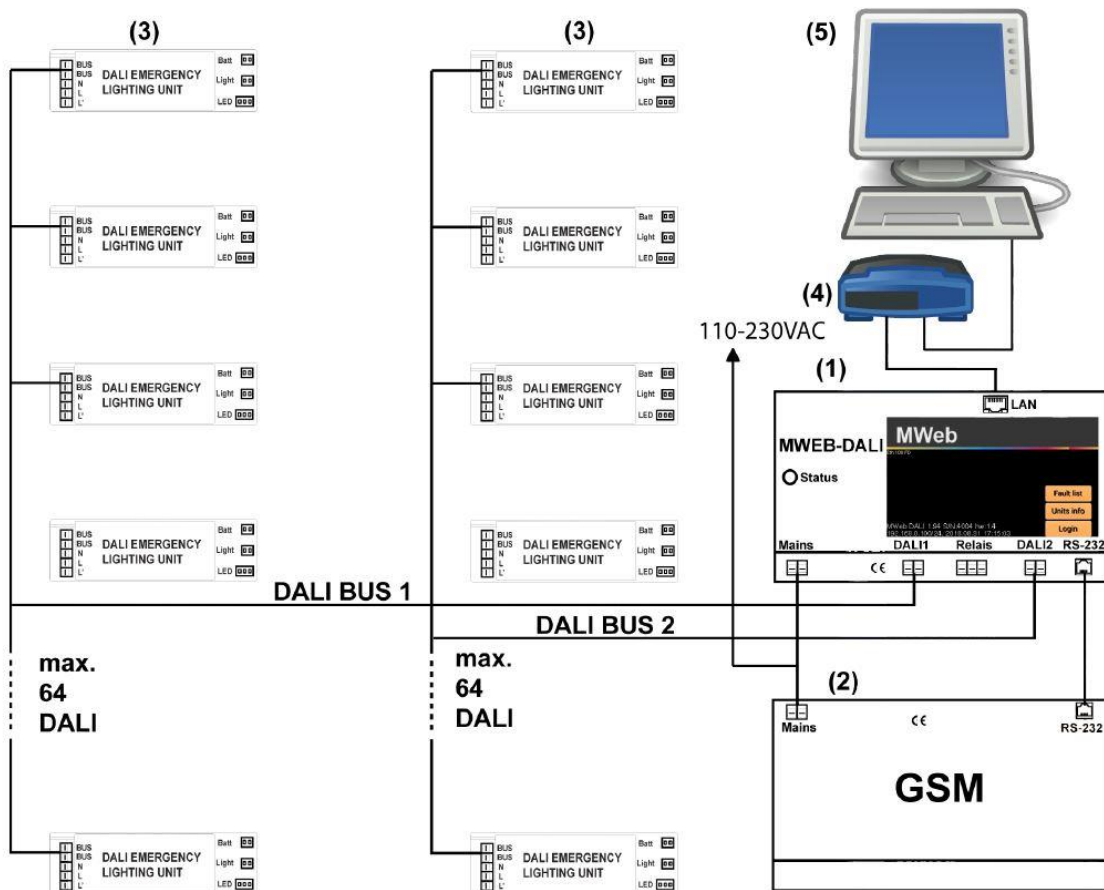

1. ZWEBDALI
2. GSM Module (optional)
3. Emergency lighting units
4. Ethernet switch
5. PC with Web browser

2 The ZWEBDALI Emergency lighting system and its elements

ZWEBDALI is used as a central supervision unit in the system communicating with the DALI protocol. There is a cyclic information exchange between the ZWEBDALI unit and each emergency lighting unit. The ZWEBDALI is continuously scanning the whole installation and gathering information about all emergency lighting units.

Note that the emergency lighting operation of each emergency lighting unit is totally independent of the supervision done by ZWEBDALI. Even in case of communication failure, emergency operation is guaranteed.

The information from the ZWEBDALI is dispatched through two independent DALI buses, each configured with up to 64 devices.

The ZWEBDALI unit is a WEB-server and can be connected to any LAN-Network communicating using the TCP-IP protocol. When addressed by a Web-Navigator software like Chrome, the ZWEBDALI unit can transmit all the information it has gathered from the emergency lighting units. This information is transmitted as HTML pages which are shown by the navigator software. Using the same software, it is also possible to change the configuration of the ZWEBDALI unit or of each emergency lighting unit.

The ZWEBDALI supervision software main tasks are the following:

- Coordination of the self-testing timing of all the emergency lighting units
- Recording of all faults
- Storage of all information concerning each emergency lighting unit
- Automatic Configuration of the System
- Data protection through password
- Sending email notifications for system status

3 Installation

The ZWEBDALI unit must be connected to the mains (85-264VAC, 47-63Hz) for its supply and to the local network using a standard Ethernet RJ45 8-pin connector.

The default value of the ZWEBDALI unit (factory setting) IP-address is 192.168.0.100. This address can be changed through the navigator software using the menu item "Configuration-general", through the system serial interface, or through the LCD configuration screen. This change will be described furthermore thoroughly and could be only performed by a system administrator.

4 Start of the software

The software can be accessed by using the web browser, at URL address <http://xxx.xxx.xxx.xxx> (where is the IP-address chosen for the ZWEBDALI unit). The configuration can be then adjusted by using the menu item "Configuration general". Additional network and email notifications configurations are available in the menu item "Network/Email".

The next step is the system configuration. In the menu item "Configuration new". The ZWEBDALI unit will find all the units connected to the system.

The starting is described with more details in the chapter 4.7 "General Configuration" and the automatic configuration in the chapter "New Configuration".

When the software has been started, and the configuration created or upgraded, the ZWEBDALI unit begins with the monitoring of all the emergency lighting units which are registered in the configuration data bank.

Admin password for configuration at ZWEBDALI is: **1234567**

User password for configuration at ZWEBDALI is: **12345**

Optional "start" password for ZWEBDALI access without configuration is: **1234**

5 Web interface

5.1 Navigation window

When the communication has been established with the ZWEBDALI unit, the following window is shown on the computer:

-Top left:

Logo or other information. This area is created with the html file FRM_HEAD.TXT, which is located on the SD card in the USER folder. Short description of customization options is on the SD card in the file /USER/README.TXT. Files on the SD card could be accessed through the FTP, with user/password credentials.

-Top right:

"emergency logo": It gives a global information about the emergency lighting system. This logo is green when everything is OK, and blinking red-yellow when there is any fault in the system.

-Center right:

Main system status area, as shown above is for non-configured system

-Center left:

system menu for system the display options and configuration – all configurations are password protected.

-Bottom left:

This area indicates the level of filling of the fault-list. This fault-list can have up to 1'000 fault entries. As soon as 900 faults have been recorded, an E-Mail can be sent to the monitoring supervisor (his address must be configured on the ZWEBDALI unit). The supervisor must then proceed with the downloading of the fault-list and its printing and/or saving, in order to erase the existing fault-list inside the ZWEBDALI unit.

-Bottom right:

Color legend for the statuses shown of the Emergency Lighting Units.

5.2 Communication-window

It is important to know that the refresh of the window is made only by the navigator software, and not by the ZWEBDALI unit. The ZWEBDALI unit is monitoring the installation independently of the navigator software and addresses one unit per second. At defined interval (default is 10 seconds), the navigator software fetches from ZWEBDALI the actual status of the installation. If the refresh timeout is set to 0, refreshes are disabled, and status will be refreshed with the “Link” button from the system menu.

This status is shown as described on the following picture, i.e. all emergency lighting units connected to the same collector box shown in one table, and each unit pictured with a color corresponding to its status. The color legend is shown on the bottom line. The unit with a thick dark border is the unit being currently accessed.

The screenshot shows the ZWEBDALI web interface. The browser address bar displays '192.168.10.150/INDEX.HTM'. The page title is 'ZEMPER ZWEBDALI'. The main content area shows the following information:

Sunday 2 Sep 2018 18:59:29, MWEB-DALI - 192.168.10.150/24
 Activity: Loop-0, Device-3 (52)
 Loop: 0 [24]

0	1	2	3	4	5	6	7	8	9	10	11
12	13	14	15	16	17	18	19	20	21	22	23

Loop: 1 [30]

0	1	2	3	4	5	6	7	8	9	10	11
12	13	14	15	16	17	18	19	20	21	22	23
24	25	26	27	28	29						

Built: Sep 2 2018, 18:36:34

At the bottom, a color legend defines the status of each unit:

- OK (Green)
- Defective (Red)
- Not ready for tests (Cyan)
- Mains failure (Orange)
- Not supervised (Blue)
- No information (Grey)
- Long test (Dark Red)
- Short test (Light Green)
- Inhibit (Yellow)
- Identification (Magenta)

5.3 Unit Information

By clicking on the rectangle corresponding to one emergency lighting unit on the window described above, all the information concerning this unit (and stored in the ZWEBDALI unit) appears on the screen as shown below:

Loop: 0 Device: 15
 Prev Next Change the parameters

Type information

Installation: 2 Sep 2018 SN:305397775 LEHF 2 Cells 4.5Ah NiCd 180 min. Version:0.5 Group:0x0

Test Information

Test day: Wednesday Test time: 12:00 Next Test: 5 Sep 2018 long testing Last test:

Em.L.-unit infos

■ No link - Check Em.L.-unit and Dali-Bus

Emergency mode	Emergency status	Failure status	Gear status	Features
■ Rest	■ Inhibit	■ Circuit	■ Gear failure	■ Integrated emergency
■ Standby	■ Function test OK	■ Battery capacity	■ Lamp failure	■ Maintained control
■ Emergency	■ Duration test OK	■ Battery charging	■ Lamp on	■ Switched maintained
■ Ext. Emergency	■ Battery full	■ Lamp	■ Limit error	■ Autotest capability
■ Function test progress	■ Function test pending	■ Function test max. delay	■ Fade running	■ Adjustable emergency level
■ Duration test progress	■ Duration test pending	■ Duration test max. delay	■ Reset state	■ Hardwired inhibit
■ Hardwired inhibit	■ Identification	■ Function test	■ Missing short address	■ Physical selection
■ Hardwired power on	■ Selected	■ Duration test	■ Power failure	■ Reserved

Charge of battery: 100%, Lamp time: 16h, Emergency: 2h

Location

Plan

Prev/Next:

Selects previous/next element from the devices list

Change parameters:

Opens the window where all the parameters concerning the unit can be modified (see paragraph below for a detailed description).

Type information:

Besides the installation date and S/N, the type information is only displayed for the DALI units providing unit type information in the DALI memory bank 2.

Test day / Test time:

It is possible to define and record when the self-testing of each unit must take place. As the battery is fully discharged after a monthly test, it is important to perform these tests when the chance of having somebody present in the room is very small. It is also important to ensure that two adjacent fittings are not going to be tested at the same time. For that reason, the emergency lighting units can be divided in groups, one with all units having even numbers, the other one with all units having odd numbers. It is then possible to define a test-day and a test-time for each group. It is also possible to define an individual test day and time for each emergency lighting (see paragraph 4.1.1.1.)

Last Test:

Gives the date when the last self-testing has been performed. Note that, if the computer has been disconnected or if the communication has been interrupted for a long period,

then the unit has been testing itself using its own internal clock, and in that case, the date recorded in the computer may be erroneous. When the communication is working again, the testing date using the unit internal clock has not been recorded by the unit, and therefore cannot be transmitted to the computer.

Installation:

Gives the date when the emergency lighting unit has been recorded in the configuration file.

Lamp replaced / Charging fault cleared / Batt. replaced:

Give the dates when the battery or the lamp were last replaced, or when the charging fault was last cleared. Note that this information is given by the unit itself to the ZWEBDALI unit.

If the battery has been tested and reported faulty (after a duration test), the unit is waiting for the faulty battery to be disconnected and for a new one to be connected. As soon as this has been done, and when the unit is asked for its status by the ZWEBDALI unit, it reports that the battery has been changed. The date of reporting is recorded inside the ZWEBDALI unit.

If the lamp has been tested and reported faulty (after a weekly function test), the unit tries to test the lamp during a few seconds each minute. As soon as the faulty lamp has been changed (after max. 1 minute), the unit reports back this change to the ZWEBDALI unit.

Location / Plan:

It is possible to allocate a text and/or graphical file to each emergency lighting unit, to describe the location of the emergency lighting unit. The image file can be of any type, which could be displayed by the web browser.

5.4 Parameters modification

192.168.10.150/datendali.htm?element=15 - Google Chrome

Nicht sicher | 192.168.10.150/datendali.htm?element=15

Device 0:15 Parameters

LEHF,3 cells,4.5Ah NiCd,180,v0.5,SN:305397775

Em.L.-unit under supervision:

Location

Device image

Em.L.-unit test day and time

Test day: Test time:

Bus address modification

New number:

Program group

0 1 2 3 4 5 6 7 8 9 10 11 12 13 14 15

Send mails on these faults

Circuit failure: Charging fault: Weak battery:
 Faulty lamp: Function test delay: Duration test delay:
 Function test: Duration test: Communication:
 Mains failure:

Single order

Status	Identification	Identification off
Em. operation disable	Em. operation enable	Start rest
Function test	Duration test	Stop test
Light on	Light off	Reset

Em.L.-unit under supervision:

By selecting “unchecked”, it is possible to disable the monitoring of this unit, without removing it from the configuration. This means that faults related to this unit will not be recorded nor shown. This feature is typically used when one unit is removed for

maintenance or completely switched off (including battery) because of the building renovation.

With controls in this window, it is possible to define or modify both the location and the plan file. The plan file is located on the ZWEBDALI SD card unit. This file has to be stored in the "PICTURES" directory which can be accessed with FTP transfer.

It is also possible to change the bus number of the emergency lighting unit. Just enter the new number and click on "go" to proceed to the change.

The emergency lighting unit can also join one or more groups. Just select the group and click on "go" to proceed to the change.

When a fault is detected, the ZWEBDALI unit is able to send E-Mails to the installation supervisors (name "admin"). Just select on the fault list, the faults for which the E-Mail has to be sent.

You can also make single tests with one unit. Results will appear in the bottom text area.

5.5 Device list

Monday 3 Sep 2018 10:47:14, Device list from: MWEB-DALI - 192.168.0.100/22

Loop 0

Device	GTIN	ID	FW Ver	Type	ELU Type	Serial number	KW	Cells	Capacity	Status	Em. mode	Em. status	Failure	Duration	Result	Battery	Lamp time	Emergency	Group	Location	
1		45C30AA3	0x107	1	LENC	1170410147	0517	2	4.5Ah NiMH	0x02	Normal	0x0E	0xC8	180	0	100%	780h	3h	0x0000	Stairwell 1	
11		82C31180	0x107	1	LENC	2193822080	0218	2	4.5Ah NiCd	0x22	Normal	0x0C	0x88	180	0	100%	4h	1h	0x0000	Hall 1	
18		92B10020	0x209	1	LEHF	2461073440	1818	6	1.8Ah NiCd	0x20	Normal	0x0C	0x00	180	6	100%	72h	72h	0x0000	Hall 2	
19		A1B10408	0x212	1	LEHF	2712732680	3318	4	4.5Ah NiCd	0x20	Normal	0x0C	0x00	180	6	100%	68h	67h	0x0000	Stairwell 2	
20		A1B10409	0x212	1	LEHF	2712732681	3318	4	4.5Ah NiCd	0x22	Normal	0x0E	0xC8	180	0	100%	4h	1h	0x0000	Entrance	
21		92AB1B40	0x209	1	LEGR	2460687168	1818	2	1.8Ah NiCd	0x20	Normal	0x08	0x00	180	6	100%	48h	46h	0x0000		
29	049A2BA5F267	251608D3	0x102	1						0x21	Normal	0x04	0x82	180	170	88%	68h	68h	0x0000		
27		00000000	0x2100	6						0x04										0x0000	
30			0x0	0						0x00										0x0000	
31			0x0	0						0x00										0x0000	
32		A0C302B6	0x212	1	LENC	2697134774	3218	2	1.8Ah NiCd	0x80	Normal	0x0C	0x00	180	6	100%	28h	26h	0x0000		
33		A0C302A4	0x212	1	LENC	2697134756	3218	2	1.8Ah NiCd	0x80	Normal	0x0C	0x00	180	6	100%	20h	19h	0x0000		
34		A0C302A0	0x212	1	LENC	2697134752	3218	2	1.8Ah NiCd	0x00	Normal	0x0C	0x00	180	6	100%	20h	19h	0x0000		
35		A0C302A2	0x212	1	LENC	2697134754	3218	2	1.8Ah NiCd	0x00	Normal	0x0C	0x00	180	6	100%	20h	19h	0x0000		
36		A0C302B2	0x212	1	LENC	2697134770	3218	2	1.8Ah NiCd	0x00	Normal	0x0C	0x00	180	6	100%	20h	19h	0x0000		
37		A0C302A6	0x212	1	LENC	2697134758	3218	2	1.8Ah NiCd	0x00	Normal	0x0C	0x00	180	6	100%	20h	19h	0x0000		
38		A0C302B0	0x212	1	LENC	2697134768	3218	2	1.8Ah NiCd	0x00	Normal	0x0C	0x00	180	6	100%	28h	25h	0x0000		
39		A0C302B4	0x212	1	LENC	2697134772	3218	2	1.8Ah NiCd	0x00	Normal	0x0C	0x00	180	6	100%	20h	19h	0x0000		

Loop 1

Device	GTIN	ID	FW Ver	Type	ELU Type	Serial number	KW	Cells	Capacity	Status	Em. mode	Em. status	Failure	Duration	Result	Battery	Lamp time	Emergency	Group	Location
0	A2BB2892	0x212	1	LEIK	2730174610	3418	2	4.5Ah NiMH	0x00	Normal	0x0C	0x00	0x00	6	6	100%	16h	14h	0x0000	
1	A2BB2868	0x212	1	LEIK	2730174568	3418	2	4.5Ah NiMH	0x00	Normal	0x0C	0x00	0x00	6	6	100%	8h	7h	0x0000	
2	A2BB2891	0x212	1	LEIK	2730174609	3418	2	4.5Ah NiMH	0x00	Normal	0x0C	0x00	0x00	6	6	100%	16h	14h	0x0000	
3	A2BB2863	0x212	1	LEIK	2730174563	3418	2	4.5Ah NiMH	0x00	Normal	0x0C	0x00	0x00	6	6	100%	8h	7h	0x0000	
4	A2BB2890	0x212	1	LEIK	2730174608	3418	2	4.5Ah NiMH	0x00	Normal	0x0C	0x00	0x00	6	6	100%	16h	14h	0x0000	
5	A2BB2898	0x212	1	LEIK	2730174616	3418	2	4.5Ah NiMH	0x00	Normal	0x0C	0x00	0x00	6	6	100%	8h	7h	0x0000	
6	A2BB2861	0x212	1	LEIK	2730174561	3418	2	4.5Ah NiMH	0x00	Normal	0x0C	0x00	0x00	6	6	100%	16h	14h	0x0000	
7	A2BB2860	0x212	1	LEIK	2730174560	3418	2	4.5Ah NiMH	0x00	Normal	0x0C	0x00	0x00	6	6	100%	8h	7h	0x0000	

Device list shows installation information about the devices in the system. Information displayed depends on the device type, emergency lighting devices have type 1. Unit name and battery information depends in this information is provided in the manufacturer specific location in the ELU memory banks. Some information is not required by the DALI standard. The unit Location is defined and stored on the ZWEBDALI unit.

5.6 Existing fault-list

Monday 3 Sep 2018 11:12:10, Current faults from: MWEB-DALI - 192.168.0.100/22

	Date	Time	Device	Fault	Location	Help
1	3 Sep 2018	11:03:35	0:1	Faulty lamp	Stairwell 1	Replace lamp
2	3 Sep 2018	11:03:35	0:1	Function test	Stairwell 1	
3	3 Sep 2018	11:03:35	0:1	Duration test	Stairwell 1	
4	3 Sep 2018	11:03:36	0:11	Faulty lamp	Stairwell 2	Replace lamp
5	3 Sep 2018	11:03:36	0:11	Duration test	Stairwell 2	
6	3 Sep 2018	11:03:36	0:16	Communication	Stairwell 3	Check the connection to the device
7	3 Sep 2018	11:03:37	0:17	Communication	Stairwell 4	Check the connection to the device
8	3 Sep 2018	11:03:39	0:20	Faulty lamp	Entrance 1	Replace lamp
9	3 Sep 2018	11:03:39	0:20	Function test	Entrance 1	
10	3 Sep 2018	11:03:39	0:20	Duration test	Entrance 1	
11	3 Sep 2018	11:03:39	0:21	Communication	Entrance 2	Check the connection to the device
12	3 Sep 2018	11:03:41	0:26	Weak battery		Replace battery
13	3 Sep 2018	11:03:41	0:26	Duration test		

When an emergency lighting unit reports a fault to the ZWEBDALI unit, this fault will be recorded automatically. In the above shown window, all the existing registered faults are shown, listed by Circuit number and the device bus address. This window is automatically refreshed each 10 seconds, so that it is possible to be informed about the status of the installation just by leaving the navigator software running and this window opened.

Date - Time	Indicates the date and time of the recorded fault.
Device	Bus address of the faulty device and the corresponding Circuit number.
Fault	Fault description
Location	Location of the unit (as registered in the ZWEBDALI unit)
Help	What has most likely to be done to repair the emergency lighting.

The faults are recorded and listed according to their order of appearance. They remain listed, even when the emergency lighting has been repaired. This window is not refreshed each 10 seconds.

Up to 1000 faults can be recorded. When more faults have to be recorded, the older faults are being erased. The filling status of the fault-list is shown on the bottom left part of the window. The installation supervisor can empty this list (see "configuration general").

In order to save the fault-list on the Computer, the following procedure has to be done:

- Right mouse click on the fault-list.
- In the menu, choose "show source text"
- In the text editor, choose "save under..."
- Choose a name ending with the htm, and a directory where the history has to be recorded.

By opening the file in this directory, it is possible to print it or save it on disk.

5.7 Test record

Monday 3 Sep 2018 11:14:58, Test record from: MWEB-DALI - 192.168.0.100/22

Device	Installation	Commissioning test	Last test	Fault	Battery changed	Charging fault cleared	Lamp changed	Serial number	Location	Next test
0.1	29.8.2018,13:43:11		None,23.4.1972,11:20:32	Lamp				1170410147	Stairwell 1	0,0,5.9.2018,12:00:00
0.11	29.8.2018,13:43:15		None,23.4.1972,11:20:32	Lamp				2193822080	Stairwell 2	0,0,5.9.2018,12:00:00
0.16	29.8.2018,13:43:18		None,23.4.1972,11:20:32	Communication				2630092136	Stairwell 3	0,0,9.9.2018,12:00:00
0.17	29.8.2018,13:43:21		None,23.4.1972,11:20:32	Communication				2630092135	Stairwell 4	0,0,5.9.2018,12:00:00
0.18	29.8.2018,13:43:24	2.9.2018,10:00:08	Duration,17.12.2020,19:42:32	No errors				2461073440	Hall 1	2,0,9.9.2018,12:00:00
0.19	29.8.2018,13:43:26		None,23.4.1972,11:20:32	No errors				2712732680	Hall 2	0,0,5.9.2018,12:00:00
0.20	29.8.2018,13:43:29		None,23.4.1972,11:20:32	Lamp				2712732681	Entrance 1	0,0,9.9.2018,12:00:00
0.21	29.8.2018,13:43:32		None,23.4.1972,11:20:32	Communication				2630156718	Entrance 2	0,0,5.9.2018,12:00:00
0.23	29.8.2018,13:43:35		None					2460687168		0,0,5.9.2018,10:00:00
0.26	29.8.2018,13:43:38	2.9.2018,10:00:11[172/180]	Duration,2.9.2018,10:00:11	Battery duration[170/180]				622201043		2,0,9.9.2018,10:00:00
0.32	29.8.2018,13:43:42	2.9.2018,10:01:01	Duration,2.9.2018,10:01:01	No errors				2697134774		2,0,9.9.2018,10:00:00
0.33	29.8.2018,13:43:45		None					2697134756		0,0,5.9.2018,10:00:00
0.34	29.8.2018,13:43:48		None					2697134752		0,0,9.9.2018,10:00:00
0.35	29.8.2018,13:43:51		None					2697134754		0,0,5.9.2018,10:00:00
0.36	29.8.2018,13:43:54		None					2697134770		0,0,9.9.2018,10:00:00
0.37	29.8.2018,13:43:57		None					2697134758		0,0,5.9.2018,10:00:00
0.38	29.8.2018,13:45:00	2.9.2018,10:01:05	Duration,2.9.2018,10:01:04	No errors				2697134768		2,0,9.9.2018,10:00:00
0.39	29.8.2018,13:45:02		None					2697134772		0,0,5.9.2018,10:00:00

This table shows following information:

- Date of installation
- Date of the first duration test (commissioning test)
- Date of the last started test and test type
- Failures at the present time
- Date of the last battery change
- Date of the cleared charging fault
- Date of the of the last lamp change
- Location
- Type of the next test (0-Duration, other-Function) and test Date and time

5.8 All tests

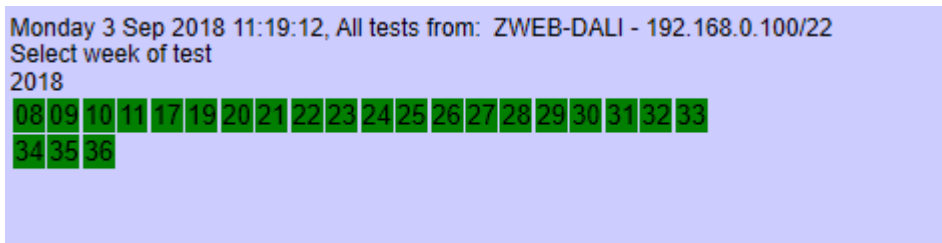

This picture shows all the tests that have been executed. Under each year the executed test weeks should be displayed. If you select one week you can see the test results off all the emergency units in this week (see the next picture).

The ZWEBDALI save the last test result for four years ago. The test result shall be saved one time a week. The saving day and time should be configured in the menu “*configuration test*”.

Monday 3 Sep 2018 11:20:35, Test record from: MWEB-DALI - 192.168.0.100/22
Test record: **Monday 13 Aug 2018 06:00:00**
<< WEEK3318 >>

Device	Inst	Test	Result	Location
0.11	x	Long test	Defective lamp	Stairwell 2
0.16	x	Long test	No errors	Stairwell 3
0.18	x	Long test	No errors	Hall 1
0.19	x	Long test	No errors	Hall 2
0.23	x	Long test	No errors	
0.26	x	Long test	No errors	
0.32	x	Long test	No errors	
0.33	x	Long test	No errors	
0.34	x	Long test	No errors	
0.35	x	Long test	No errors	
0.36	x	Long test	No errors	
0.37	x	Long test	No errors	
0.38	x	Long test	No errors	
0.39	x	Long test	No errors	
1.1	x	Long test	No errors	
1.2	x	Long test	No errors	
1.3	x	Long test	No errors	
1.4	x	Long test	No errors	
1.5	x	Long test	No errors	
1.6	x	Long test	No errors	

5.9 Administrator Configuration

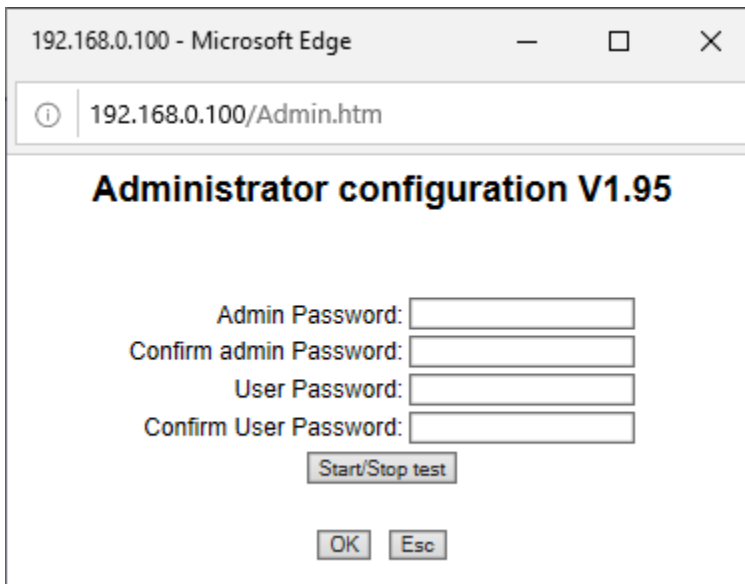

192.168.0.100 - Microsoft Edge
192.168.0.100/Admin.htm

Administrator configuration V1.95

Admin Password:
Confirm admin Password:
User Password:
Confirm User Password:

-Passwords

The installation supervisor will have to choose and confirm a password. He will be called “admin” (administrator) and will have the right to modify everything. He can also modify the “user” password. This is very useful if the user has lost his password

-Start/Stop test

The administrator can start or stop function and duration tests for all or a part of units in the installation. The test will only start if the Em.L.-Unit is ready for tests.

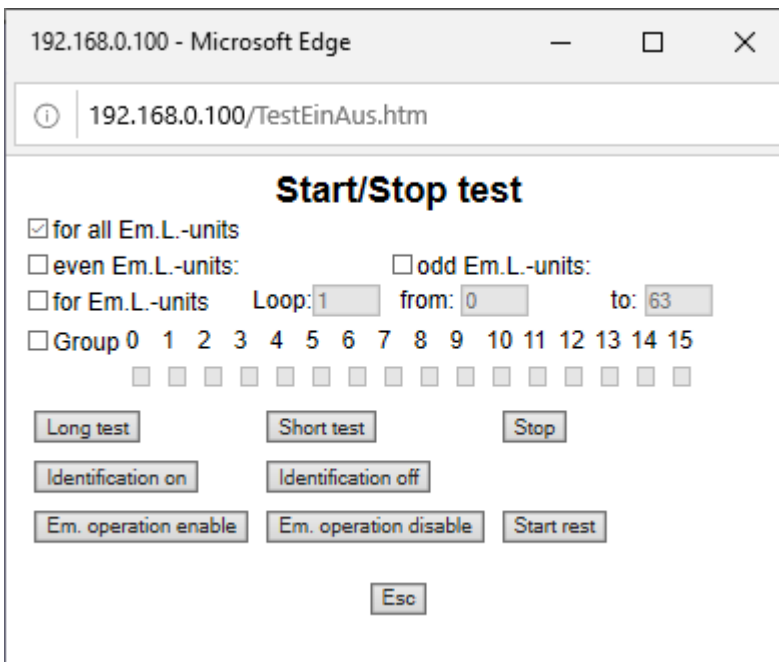

192.168.0.100 - Microsoft Edge
192.168.0.100/TestEinAus.htm

Start/Stop test

for all Em.L.-units
 even Em.L.-units: odd Em.L.-units:
 for Em.L.-units Loop: from: to:
 Group 0 1 2 3 4 5 6 7 8 9 10 11 12 13 14 15

-Identification on/off

The administrator can start or stop identification for all or a part of units in the installation. During identification the status led is blinking Red/Green. This identification status led is only blinking if the Em.L.-Unit is not faulty.

The identifications to be stopped by depressing the "Identification off" push button.

-Long/short test

The administrator can start the Duration or Function test for all or a part of units in the installation.

-Emergency operation disable

In case of intentional power disconnection, all units should be put into the Emergency Inhibit mode, so battery is not discharged. This is used for closing facility for night. The Emergency inhibit would be active for 15 minutes (DALI standard requirement), or until terminated by pressing "Emergency operation enable" button

-Start rest

If the units are in the emergency operation mode, administrator could switch emergency light off for all or selected devices.

5.10 General Configuration

The screenshot shows the 'General Configuration ZWEBDALI v2.10' web interface. At the top, there are language selection options: Deutsch, Français, and English (selected). Below this, there are input fields for 'User Password', 'Confirm User Password', 'User ID admin', 'Login Password', and 'Confirm login Password'. A checkbox for 'Login requested' is also present. The 'Server name' is set to 'ZWEBDALI' and 'ModBus' is set to '0x80'. There are six input fields for 'Contact line 1' through 'Contact line 6'. A 'Date and time setting' section shows 'DD/MM/YYYY' as '28/01/2019' and '17:59' with an 'Ok' button. A 'Fault history filling state' section shows '0/1000 in use' and a 'Clear' button, with a warning: 'Warning! Before you clear the fault history, save it on your PC'. An 'Evacuation setup' section has a label 'In case of fire enable or disable to switch on all Em.L.-units for evacuation' and radio buttons for 'Enable' and 'Disable' (selected). An 'Em.L.-units cycle time' section has a label 'Time in milliseconds (min. 1000, max. 4000)' and an input field with '1500'. A 'Configuration options' section contains several checkboxes: 'Show color legend' (checked), 'Hide header' (unchecked), 'Hide menu' (unchecked), 'Show error icon' (checked), 'Show location' (unchecked), 'Show unit's number' (checked), 'Show errors level' (checked), and 'Show groups' (unchecked). At the bottom, there are 'Save' and 'Exit' buttons, and a 'Touchscreen calibration' button.

The following parameters can be defined or modified:

-Language

-Password

The installation supervisor will have to choose and confirm a password.

He will be called “user” and will have the right to modify everything except the administrator password.

He can also define a login password. In this case the server can be accessed as “admin” and his password or as “user” with the login password.

-Server name

Name of the ZWEBDALI server

-Date and time setting:

The ZWEBDALI unit has an internal clock, in order to register the faults. Use the corresponding fields to modify and/or adjust the clock data.

-Fault list filling state:

When the fault-list has to record more than 1'000 faults, the oldest one will be erased. In order to prevent this, the fault list should be regularly emptied (press on “erase”)

ATTENTION: before erasing the existing list, the fault-list should be recorded and printed. Please see paragraph 4.3 to save the fault-list.

-Evacuation:

By selecting “enable” and then “OK” at the bottom, all the emergency lighting units will be able to be switched on and running in emergency mode (i.e. discharging their batteries) by closing a local contact on the ZWEBDALI unit. This can be used for example in case of fire. This local contact is between RTS and CTS on the system RS232 interface of the ZWEBDALI unit (normally open, emergency operation when closed).

-Devices scan cycle time:

Setting of the time interval between accesses for two devices (between one Em.L.-unit and the next one).

5.11 Network/mail Configuration

Network and mail configuration ZWEBDALI v2.10 Eth 100 FD

TCP/IP parameters

<input checked="" type="checkbox"/> Use DHCP	<input type="text" value="10.0.0.210/24"/>	MAC	<input type="text" value="0003F40BF8A1"/>
IP	<input type="text" value="10.0.0.210"/>	Mask	<input type="text" value="255.255.255.0"/>
Gateway	<input type="text" value="192.168.0.1"/>	DNS	<input type="text" value="192.168.0.1"/>
Server 1	<input type="text"/>	Wired	<input type="text" value="0"/>
Server 2	<input type="text"/>	Wired	<input type="text" value="0"/>
Status	<input type="text"/>	Wired	<input type="text" value="0"/>
FTP server	<input type="text"/>	port	<input type="text" value="21"/>
FTP server user	<input type="text"/>	pwd	<input type="text"/>

Monthly
 Weekly
 Daily

E-Mail parameters

Mail output server	<input type="text"/>	port	<input type="text" value="25"/>
Password	<input type="text"/>	<input type="checkbox"/> with authentication	<input type="checkbox"/> SSL <input type="checkbox"/> TLS
User ID	<input type="text"/>		
System e-mail address	<input type="text"/>		
admin e-mail address 1	<input type="text"/>	<input type="button" value="Mail Test"/>	
admin e-mail address 2	<input type="text"/>	<input type="button" value="Mail Test"/>	

Send mails on these faults

for all Em.L.-units

Circuit failure: <input checked="" type="checkbox"/>	Charging fault: <input checked="" type="checkbox"/>	Weak battery: <input checked="" type="checkbox"/>	Defective lamp: <input checked="" type="checkbox"/>
Function test delay: <input checked="" type="checkbox"/>	Duration test delay: <input checked="" type="checkbox"/>	Function test: <input checked="" type="checkbox"/>	Duration test: <input checked="" type="checkbox"/>
Communication: <input checked="" type="checkbox"/>	Mains failure: <input checked="" type="checkbox"/>		

Send one mail per month (max. 50 faults)

Send one mail per week (max. 50 faults)

Send one mail per day (max. 50 faults)

-Mail Configuration

The ZWEBDALI unit can send automatically E-Mails to the installation supervisor, for example when the fault list is almost (90%) full.

The E-Mail parameters are usually given by your Internet Provider.

You can chose between sending a mail at each appearing of a fault or one time a day or one time a week or one time a month.

-TCP/IP parameters:

The ZWEBDALI unit is a WEB server, belonging to a local network, or to Internet. It needs an IP Address. If the ZWEBDALI unit has to send E-Mail over a gateway, the IP addresses of the gateway and of the DNS server have also to be recorded. These data should be recorded by the network administrator.

ATTENTION: as soon as new network data has been recorded, the ZWEBDALI unit restarts automatically (with for example a new IP address).

-E-mail parameters:

Ask your e-mail provider for the right setting of these parameters.

If you validate the mail sending with authentication you must enter a password and the right port number.

5.12 New system configuration

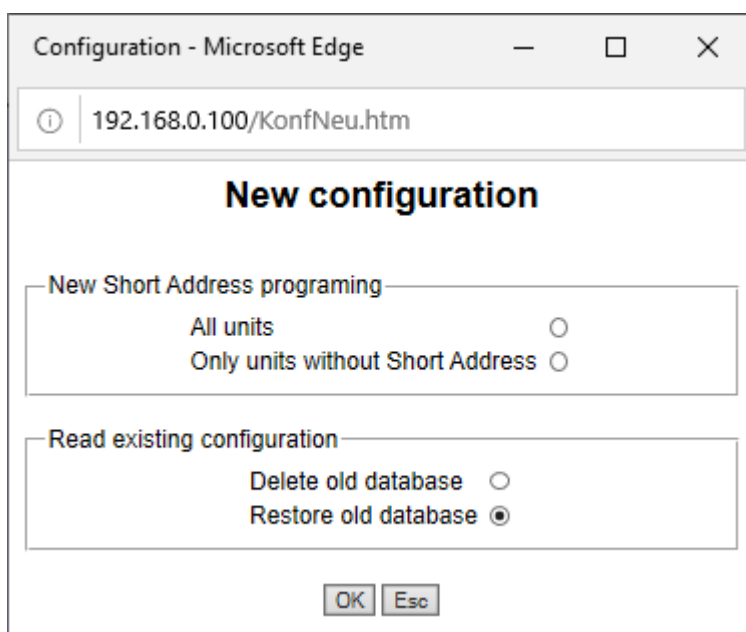

The screenshot shows a web browser window titled 'Configuration - Microsoft Edge' with the address bar containing '192.168.0.100/KonfNeu.htm'. The main content area is titled 'New configuration' and contains two sections:

- New Short Address programming**:
 - All units
 - Only units without Short Address
- Read existing configuration**:
 - Delete old database
 - Restore old database

At the bottom of the form are 'OK' and 'Esc' buttons.

By using this window, the ZWEBDALI unit is going to automatically detect the units connected in the installation. This is the simplest way to create the initial installation file. This is also the simplest way to upgrade.

Important: Be careful by updating this file, not to delete the existing one, because the file also contains the information concerning locations and test parameters for all the units. When updating, always select "restore old database".

When adding to the configuration new devices without initialized bus address, use option: Only units without Short Address

If all system needs to be reprogrammed, use option: All units.

For the bus address (Short Address) programming, ZWEBDALI is using Random address generation as defined in the DALI standard.

5.13 Test time configuration

The screenshot shows a web browser window with the address bar displaying '192.168.0.100/KonfTest.htm'. The page title is 'Test Configuration'. The main content area contains two sections:

- assign a test date and time to the even and odd Em.L.-units:** This section includes two radio buttons. The first is selected and labeled 'even Em.L.-units:'. It has a dropdown menu set to 'Sunday' and a time dropdown set to '12:00'. The second radio button is labeled 'odd Em.L.-units:' and has a dropdown menu set to 'Wednesday' and a time dropdown set to '12:00'.
- Save test record:** This section includes a dropdown menu set to 'Monday' and a time dropdown set to '06:00'. There are three checkboxes: 'Send email', 'Send to FTP', and 'Send to LOG', all of which are currently unchecked. There are also 'Clear' and 'Test' buttons.

At the bottom of the form, there are 'OK' and 'Esc' buttons.

-Test date and time:

In this window you can assign the test day and time for all the even and odd emergency units.

-Saving the test results:

Enter the test results saving day and time.

-Send email with test results:

An email with an attached file containing the test results of the last week can be send at the save test record time.

5.14 Delete emergency lighting units:

The screenshot shows a web browser window with the address bar displaying '192.168.0.100/DelElemDali.htm'. The page title is 'Delete Em.L.-units'. The main content area contains a form with the following elements:

- Em.L.-units:** A label above a form box.
- Loop:** A text input field.
- from:** A text input field.
- to:** A text input field.

At the bottom of the form, there are 'OK' and 'Esc' buttons.

It is possible to erase individual emergency lighting units from the configuration (installation file).

5.15 Special feature – remote control

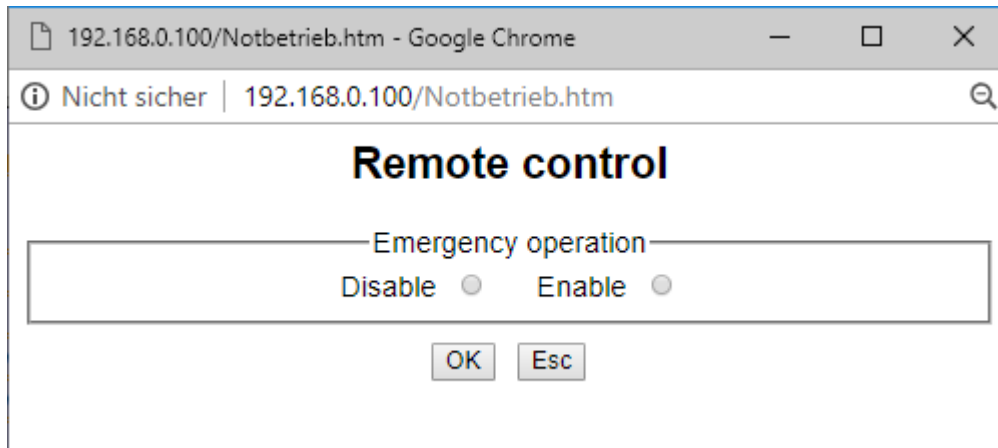

By selecting “Disable” and clicking on “OK”, on all the emergency lighting units, the emergency operation will be disabled during the next 15 minutes. This means that they will not switch over to emergency operation, even in case of mains failure. On the main screen during the main supervision procedure, the units will be shown with XX in their corresponding rectangle.

Using this feature, it is possible to switch off the mains feeding the emergency lighting without discharging the batteries. The switching off must occur within 15 minutes after having sent the “emergency operation disable” command.

The emergency operation is automatically enabled again by the units themselves as soon as the mains is switched back again (or after 15 minutes if the mains has not been switched off at all).

By selecting “Enable” and clicking on “ok”, the emergency operation can be manually enabled, without having to wait until it is done automatically again (15 minutes).

6 FTP Transfer

The configuration can be saved on computer. By doing this, it is possible to download it again at any time in the memory of the ZWEBDALI unit. The uploading and/or downloading is made by using a FTP transfer software like WinSCP or FileZilla. The FTP connection can be established with the IP address of the ZWEBDALI unit.

Username: *user*

Password: user password

You can save and restore the configuration file (with “*copy*” and “*paste*”, change the logo (in “LOGO” directory) and store pictures (in “PICTURES” directory).

If the FTP connection is established you will see the following files and directories:

PICTURES: All the used plan files must be stored in this directory.

LOGO: The logo file must be stored in this directory. The file must be named "logo.bmp"

USER: User customization files for web and LCD interfaces

At the base directory the following files are stored:

-KONFIG.WDB is the configuration file

-TESRES.DAT is the test result file

-FEHLER.FDB is the fault list file

-EVENT.LOG is an event file

The "KONFIG.WDB", "TESTRES.DAT" and the files in the "PICTURES" and "LOGO" directories are effectively stored at the SD card.

The files "FEHLER.FDB" and "EVENT.LOG" are virtual files, they are not stored at the SD card but created at the FTP transfer time.

7 Firmware low level monitor

Connection between the ZWEBDALI and a PC (only needed for local set-up and/or maintenance)

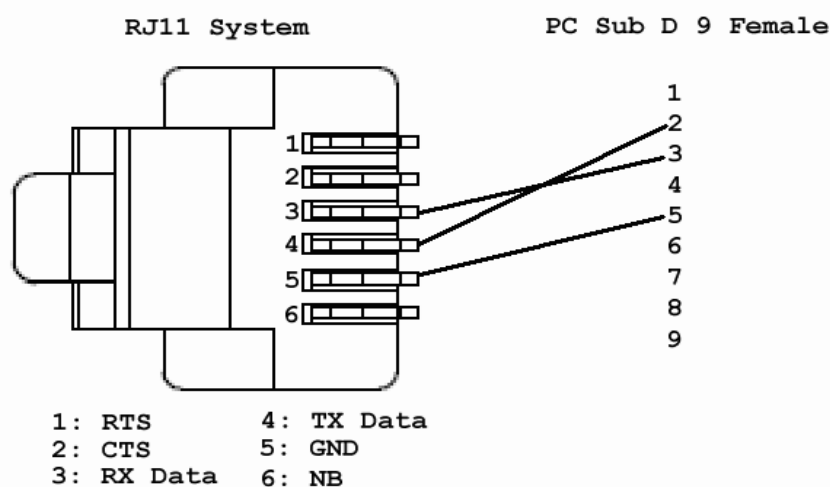

-All the information coming from the ZWEBDALI unit or shown in italics.

The ZWEBDALI unit has an internal Firmware. It is possible by using this Firmware (before the main application software starts) to get access to the internal system. In order to do this, the ZWEBDALI unit has to be connected to a computer through one of its COM-port by using the above described cable. The ZWEBDALI unit has to be restarted, and, on the computer, a software like Mttty.exe has to run (before the starting of ZWEBDALI). Mttty settings: COM1 or COM2, 115200 Bauds, 8 Bits, 1 stop, no parity.

The first message coming from ZWEBDALI after starting is the following:

"Waiting 2sec to start 'A' to abort"

You have 2 seconds to tip the letter "A". After this 2-seconds delay, the application software (supervision software and web server software) starts automatically. If you manage to tip "A" within these 2 seconds, you will get the following message:

```
"Netburner MCF Monitor V1.8 Sep12 2003 12:58:30x Alternate Image Monitor V1.00 May 29 2012  
15:25:39  
HELP for help  
nb>"
```

To get the list of all the possible commands, you have to tip "help"

The most important command is the "setup" command, because it gives you an overview of all the network parameters. By tipping "setup", you will get the following information:

```
nb>setup  
MAC address=xx-xx-xx-xx-xx-xx  
1.) IP Address =192.168.0.100  
2.) IP Mask =255.255.255.0  
3.) IP Gateway =  
4.) TFTP Server=  
5.) TFTP File =  
6.) Baudrate =115200  
7.) Wait =2  
8.) Boot to Application  
9.) Exceptions CauseReset  
A.) DNS Server =  
B.) Boot Port =0  
W.) Watchdog=disabled  
Q.) Quiet boot  
1-B to change, S to save, X to exit
```

If you want to change any of these parameters, choose the corresponding number 1 to B, give the new parameter, and don't forget to tip S in order to save the changed parameters.

The most important parameters are:

- 1) IP Adress of the ZWEBDALI unit
- 2) IP Mask of the ZWEBDALI unit
- 3) IP Gateway to the Internet Router
- 6) Baudrate of the System RS232 Interface

Please do not change any of the other parameters. These are factory settings and should not be changed.

7.1 Upgrading the application with AutoUpdate

To avoid to lose the Em.L.-unit configuration, please execute the following steps:

1. Upload the configuration (KONFIG.WDB), fault-list (FEHLER.FDB) and the test results (TESTRES.DAT) files to the PC with FTP transfer;
2. Download the new application file “mxxx_APP.s19” into the ZWEBDALI (procedure will be described below), xxx is the version number
3. ZWEBDALI will restart automatically.
4. Download from the PC the saved configuration files. with FTP transfer.

Proceed in this order please “KONFIG.WDB”, “FEHLER.FDB”, “TESTRES.DAT”

A configuration file can always be downloaded to a more recent application software (i.e.: it is upwards compatible).

Procedure to download with Autoupdate a new version of the application software to ZWEBDALI

Connect ZWEBDALI and the PC with an Ethernet cable (cross cable by direct connection)

The IP address from ZWEBDALI must be known, ZWEBDALI and PC must be on the same network. If no adjust the IP address of the PC).

- Launch “Autoupdate.exe” at the PC
- Select the ZWEBDALI IP address or start an automatic search with “Find”
- Enter the filename “mxxx_APP.s19” or use “Browse” to find it.
- Check “Reboot when complete”
- Push “Update”

The new file will be downloaded into the ZWEBDALI. Please wait until the download is completed.

After this the ZWEBDALI will reboot.

8 Return to factory settings / Restart

If you cannot get access to the ZWEBDALI unit through the LAN interface, it is still possible to:

- Restart unit
- Reset the TCP/IP address
- Get back to the factory settings

By pressing the control button with the paper clip through the hole next to the Ethernet connector, you can select three restart options:

- Pressing until first orange blink of the status LED unit is restarted only.

- Pressing for few seconds, until second status LED blink TCP/IP configuration is getting reset – IP address is set to 192.168.0.100, with DHCP enabled
- Pressing until 3rd blink of the status LED, will cause clearing all configuration back to the factory settings.

9 LCD touchscreen operation (optional)

The ZWEBDALI could be equipped with the LCD display with touch control.

For the uninitialized system, the LCD will look as shown below.



The information shows Ethernet connection status, device IP address, and user button allowing for the login. Since the device is not configured, all default passwords are shown. After system is configured, password information will not be shown any more. For the configured system initial LCD status will be shown as below.



9.1 Basic system configuration with LCD interface

For the “admin” user, after successful login, the bottom right button will be shown as “Config”. For the non-admin users, it will be shown as “Logout”. ZWEBDALI allows to have up to 8 different users. Additional users are configured with the telnet interface described in the following chapters.

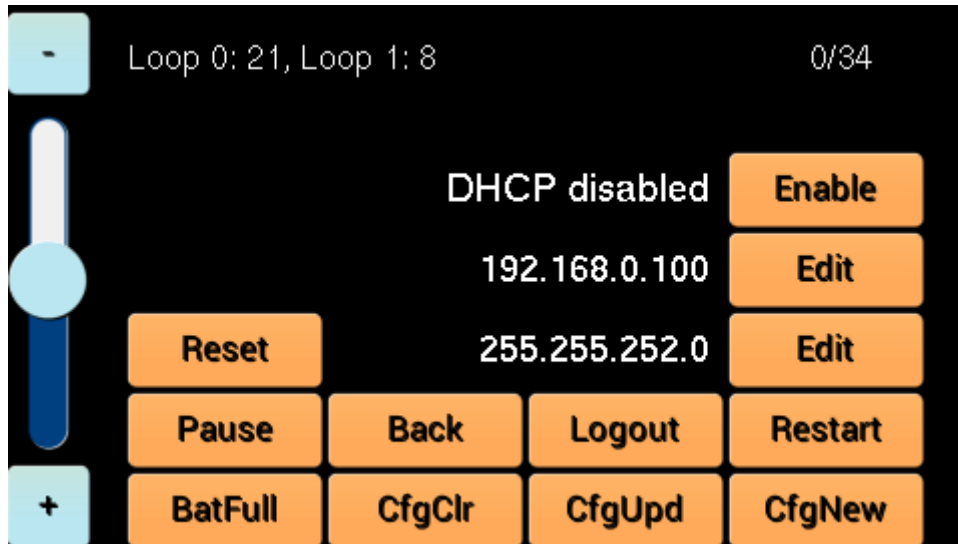

The scrollbar on the left side allows to set the level of the LCD back light. This is saved in the non-volatile memory. The LCD screen timeout could be configured with the “set lcdto secs” command from the telnet interface.

9.1.1 IP address configuration

DHCP operation can be disabled or enabled with the top right button. If it is enabled, and the DHCP server is running on the network, device’s IP address will be requested from the server, and the device will provide server with its name consisting of word “MWEB” and low 3 bytes of the ethernet controller’s MAC address.

For static network connections IP address and mask can be edited. After changes are done, unit needs to be restarted for the changes to take effect.

9.1.2 DALI devices configuration

There are three user buttons related to the DALI bus configuration:

CfgClr : Deletes all devices which are configured on the ZWEBDALI controller

CfgUpd : Update existing configuration, by checking if there are new devices with preprogrammed bus address.

CfgNew : Will run random address configuration procedure defined in the DALI standard, to assign bus addresses to the connected devices. This will only affect devices without initialized bus address.

To clear all bus addresses, the web interface needs to be used.

9.1.3 Other configuration buttons

Reset : Broadcast DALI reset command to all devices on both DALI busses

Pause : Stop polling for the DALI devices status

BatFull : Simulate charged battery state, this is non-standard DALI command, implemented for some devices only. Non standard DALI commands are described in the telnet operation section.

Back : Return to the previous LCD screen

Logout : Log the "admin" user from the system.

9.2 DALI devices status

If there are configured devices, the „Units info“ button is shown. When selected, it will show configured devices on both busses – up to 128 devices

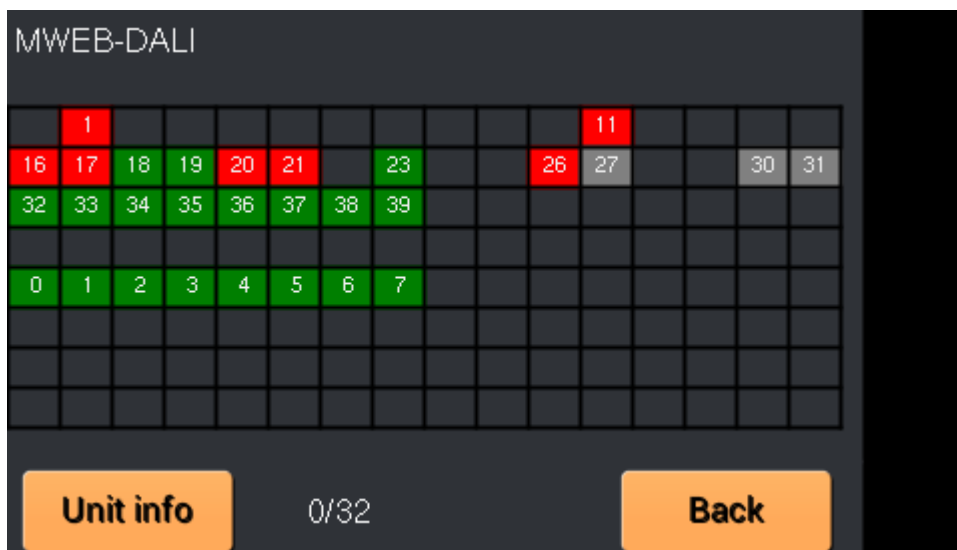

If there are DALI slave controllers configured, the scrollbar will allow to select one of the slave units for status display.

To show status of the specific device, select it. The colors are showing each device status, as defined on the web interface.

- Green - Device OK
- Red - Device error
- Cyan - Not ready for tests
- Orange - Mains failure
- Blue - Not supervised
- Grey - No information
- Brown - Long test

- Green - Short test
- Yellow - Inhibit
- Magenta - Identification

Selected device is shown with inverted color, and device information is shown on top of the display. The two numbers on the bottom are showing currently accessed device with Bus/Address values. User buttons allow to return to the previous screen, or show detailed status of the device.

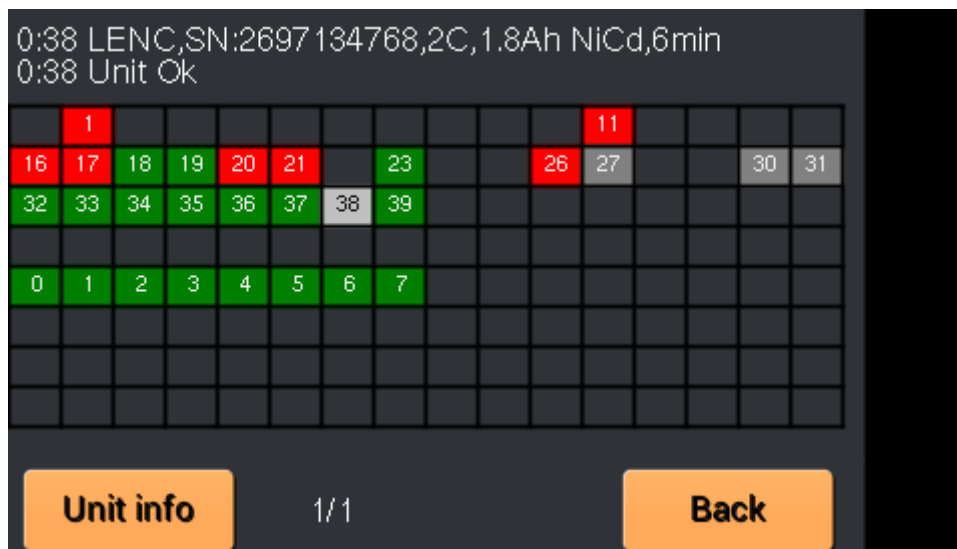

9.3 DALI device error information

The unit info screen, shows individual bits for the Failure Status register.

Detailed information below the Failure Status bits shows:

- 16-bit group register – to which groups the device belongs
- Light level – for the devices supporting DALI arc commands
- Gear status register
- DALI firmware version
- Battery charge level
- Emergency Mode register
- Emergency Status register
- Failure Status register
- The user buttons allow to select additional device controls

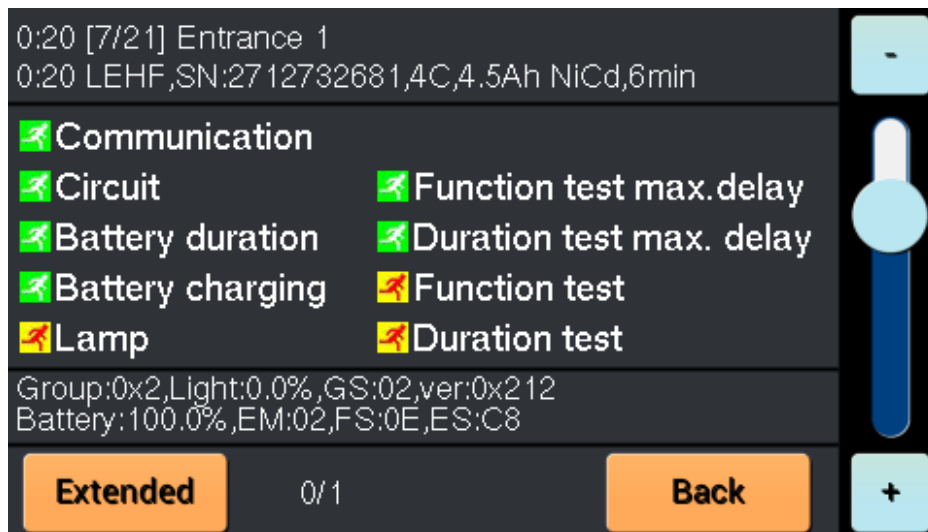

9.4 DALI device controls

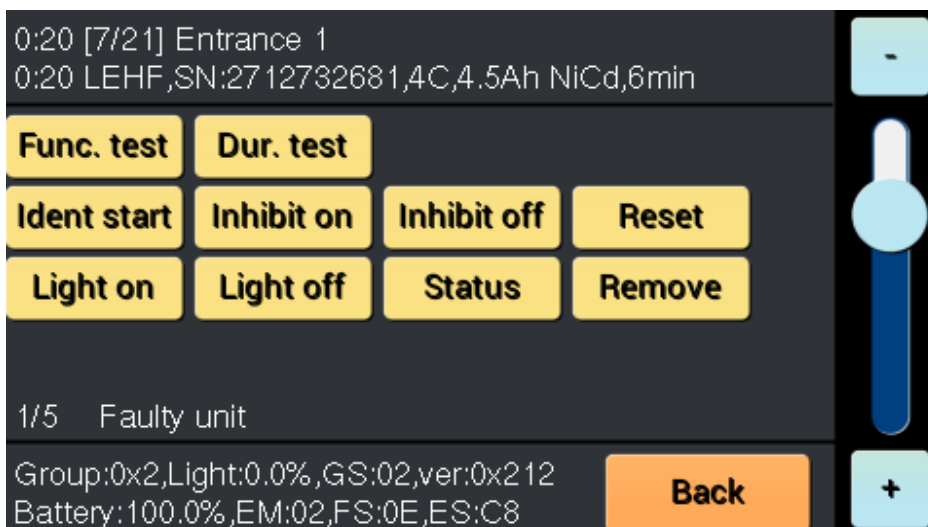

User buttons allow to execute following DALI commands:

- Start function test
- Start duration test
- Stop test (hidden if no test is running)
- Identification start/stop
- Inhibit enable (do not enter emergency mode on power failure)
- Inhibit disable (normal operation)
- Reset – send DALI reset command, clearing some error flags
- Light on/off – only for devices supporting DALI arc commands
- Status – read device's status registers
- Remove – remove device from DALI controller configuration

9.5 DALI devices fault list

If there are any errors detected for the configured devices, list of failures is available by pressing "Fault list" on the main screen.

The list shows only first error for the device, if there are multiple errors, those will be shown on the device's status screen.

Time stamp shows when specific error was detected.

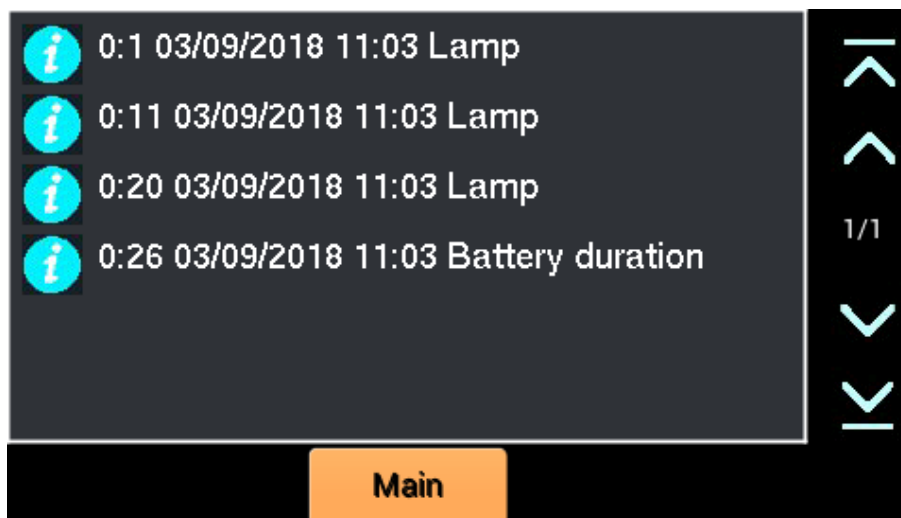

9.6 DALI devices tests

DALI tests could be executed for groups of devices:

- all
- even address
- odd address
- group 0..15

The active device selection could be changed with the right scroll bar.

- Identification start/stop
- Function/duration test start/stop
- Inhibit on/off
- Light on/off – only for devices supporting DALI arc commands
- 40/65/90% - for DALI lights supporting dimming, otherwise interpreted as light on

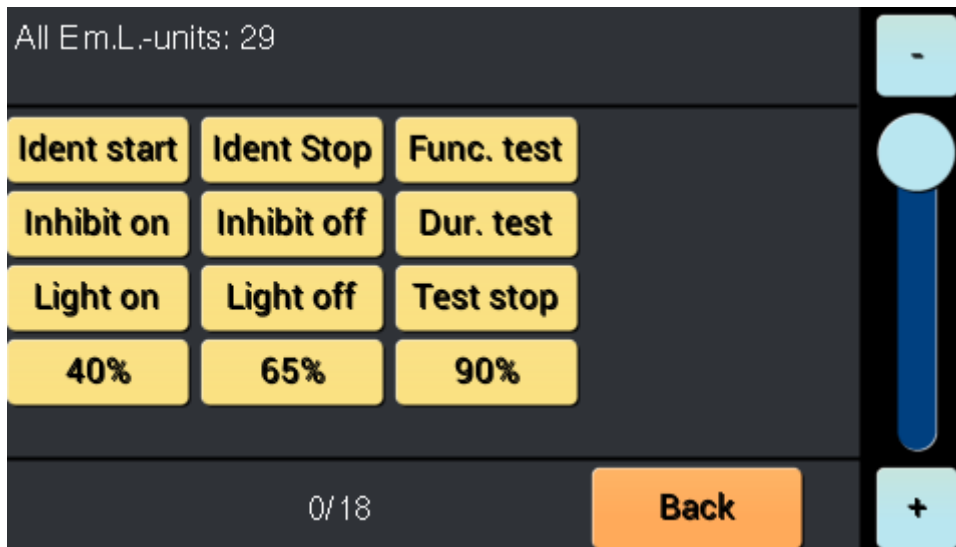

9.7 Optional information on the main LCD screen



Main screen on the LCD shows various system status. If the GSM module is installed, the LCD could show the SIM card CCID, GSM module model, connection parameters: Received Signal Strength Indicator and Bit Error Rate

For the remote access, connection 0 shows wireless connection (over GSM) to the access server and connections 1 and 2 wired (over Ethernet) connections.

Lasty line shows status of the Ethernet connection.

In this area are also shown messages if the DALI bus is shorted.

10 ZWEBDALI Telnet interface

The ZWEBDALI system provides up to 4 sessions of the Telnet server. The telnet console could be used to do the system configuration, execute low level tests, or connect another GUI for configuring or testing system.

The telnet server is waiting for client connections on port 2323. To login into the server, one of the user names with valid password needs to be used.

List of all supported commands is available with “help” command.

The “set” command is used to configure numeric and boolean parameters, which are stored in the non-volatile memory.

10.1 Telnet commands list

- ADdR [ip/bits][[ip [mask [gw [dns [0|1(dhcp)]]]]]] - set/show system address
- Boot - Reboot Netburner request
- C2CHEckerase addr size - verify if block is erased
- C2CLEAr addr - clear flash sector
- C2DERivative - get MCU device id, derivative and version
- C2DETECT - detect if MCU device present
- C2DEVICEerase - erase whole device
- C2DPin - get c2d pin level, power fail detection
- C2GETpar - get device programming parameters
- C2RESet - reset device
- C2READ addr cnt - read flash
- C2READDirect addr - read direct memory
- C2READSfr addr - read SFR register
- C2RUN - run device
- C2WRITe addr cnt val [val..] - write flash
- C2WRITEDirect addr val - write direct memory
- C2WRITESfr addr val - write SFR registger
- CAT - display SD card file (use 'tail' to limit data)
- CD [dir] - change/show SD card directory
- CLEAN - Remove empty CBoxes from configuration
- CLS [opt] - clear screen, opt will clear scrollbar
- CONFig {clear|load|save fname} | {[kbox[elem]]} - load/save/show devices configuration
- CONNect ipAddr - connect to server
- CONSOLE [0|1] - use UART for Radio console
- CONVert number - show value in dec, hex and binary
- CP src dst - copy file

-
- DALI [?|cmd par1 par2] - send cmd to DALI controller
 - DALIAdj [val] - Set DALI timing correction for edges
 - DALIDelay [val] - Set DALI interpacket delay in 10 ms counts
 - DALIFilter [val] - Filter log for DALI device (-1 dis)[debcom 1]
 - DALIInit - init DALI operation
 - DALIMem circuit element [bank [addr [val]]] - DALI memory access
 - DALIPower [0|1 [on|off]] - control DALI bus power
 - DALIReg [circuit [elem [index [val]]]] - set/get DALI register demo value (elem=-1 - all)
 - DALIStart - Initialize DALI controller
 - DALITest [circuit addr cmd par] - Send DALI test command
 - DALITO [val] - Set DALI RX timeout factor
 - DEBComm flag - set debug flags for comm
 - DEBDisp flag - set debug flags for display
 - DEBHaupt flag - set debug flags for hauptprog
 - DEBMAIL flag - set debug flags for mail
 - DEBMAIN flag - set debug flags for main
 - DEBUg flag - set debug flags
 - DEBUGLOG - reset debug log flag
 - DELAy [msec] - set intercommand delay
 - DELEte [kbox[elem[:elem]][,elem]] - Delete element range or list
 - DEVInfo [kbox [el]] - show devices
 - DIR - show SD card directory
 - DISconnect - disconnect from server
 - DNS [ip] - set/show DNS address
 - DO name - execute command file
 - DUmp [name] - execute screen shot to .bmp
 - ECho [0|1] - Enable console echo back
 - ETh - show link status
 - ERror [kbox [elem]] - show errors
 - EVENTLog {clear | save fname} | {[kbox[elem]]} - save/show system events log
 - EVent {clear | save fname} | {[kbox[elem]]} - clear/save/show system events
 - FEhler {clear | save fname} | {[kbox[elem]]} - save/show system errors
 - Filter [kbox [elem [0|1]]] - filter tx/rx packet display
 - FLCHk node addr cnt - Check if flash is erased
 - FLCLr node addr - Erase flash sector on repeater

-
- FLExec node addr - Execute user code
 - FLLEd node mode - Test led, 0-dis,1-0n,2-off,3-tog
 - FLLOCK node - Lock flash on repeater
 - FLLOCAtion node [loc] - Set/get location of repeater
 - FLIrd node addr [cnt] - Read flash on repeater
 - FLRd node addr [cnt] - Read flash on repeater
 - FLText node addr [cnt] - Read flash on repeater
 - FLVer node - Read flash fw version
 - FLWr node addr val [val] - Read flash on repeater
 - FName [name] - set file name for file operations
 - FONTInfo idx - show font information
 - FONTRd idx - read font definition
 - FUNCDef [Fx[cmd]-r] - set/get/remove function key definitions
 - FUNCLoad - load function key definitions
 - FUNCSave - save function key definitions
 - GSm cmd - process GSM command
 - GRoup INIT[[n [name]]] - process group options
 - GW [ip] - set/show gateway address
 - HAndshake [0|1] - Enable synchronization with main processing loop
 - HELP [str] - Show commands help
 - HIStory [n] - Show commands history
 - I2CRead addr reg cnt - Read I2C
 - I2CWrite addr val [val]
 - IGNOre [cnt] - ignore one or more LFs
 - INFO kbox elem - show test info for element
 - INITDir user - Initialize user folder
 - INITKonf [blocks] - Initialize configuration file
 - INITRam [1] - Initialize RAM (1 to force)
 - INITSn [s/n] - Initialize MWeb S/N
 - INITUc ver [s/n] - Initialize MWeb uc
 - IQrf str - Send IQRF command
 - IQRFI Uart# - Initialize IQRF over UART
 - IQRFL - List IQRF nodes
 - IQRFR Read IQRF UART
 - IQRFW val [va] - Write IQRF UART, and add CRC
 - IPfilter [add|del address [maskBitCnt]] - Manage IP address filter

-
- LCDBaud [kHz] - set SPI baudrate
 - LCDEna [opt] - control LCD: 0-dis refresh, 1-ena, 2-clr, 3-test pattern, 4 - init
 - LCDRd bits reg - LCD control register read (bits 8/16/32)
 - LCDShow - show LCD text iformation
 - LCDUser mode - set LCD user login status (0-none,1-user,2-admin)
 - LCDWr bits reg value - LCD control register write (bits 8/16/32)
 - LED mode - 0-off, 1-green, 2-red, 3-orange,
 - LIGHt INIT|ON|OFF|[[a] mac|kbox:elem on|off|[page row col]] - enable light switch processing
 - LOCation [mac|kbox[:elem]] [string|-r] - set/get/remove item location string
 - LOGUart [on|off] - setUART logging
 - MAIL - show mail configuration
 - MEMory {map|addr [cnt]} - display memeory
 - MESh - configure mesh network
 - MKDIR name - create SD card directory
 - MODbus [addr] | [kbox elem idx val] - get/set ModBus slave address, or set demo error codes
 - MONitor [0|1 [ena|dis|get|auto|forw]] - control DALI monitor operation on a bus
 - MQTt - test mqtt connection
 - MRD addr [cnt] - read from MRAM
 - MRI val - initialize MRAM with value
 - MRT val len - MRAM tests
 - MWR addr [val []] - write values into MRAM
 - MWEBTest - run MWEB tests
 - NBDEbug flags - set netburner debug flags
 - NBTAsklist - Show Tasks List
 - NBDUmptasks - Dump Tasks
 - OPRBaud [index] - Set baudrate for UART for opradio (0..7)
 - OPRDebug [retry cnt] - Get radio debug information
 - OPRCmd mode dst addr1 addr2 par1 par2 - Send opradio command
 - OPRInit [uart] - init UART for opradio
 - OPRMac show|load|save|[iqaddr [iqaddr]] - Get/show/save/load routing table
 - OPRRTG mac - get route table from device
 - OPRRTS - Save route tables into EEPROM - opradio
 - OPRRR - RX raw data from UART for opradio
 - OPRRX - RX values from UART for opradio
 - OPRSHow - Show devices routing tables

-
- OPRStatus - get status of UART for opradio
 - OPRTR [val val] - TR values to UART for opradio
 - OPRTX [val val] - TX values to UART for opradio
 - OPRUart [val [val]] - low level uart service for UART for opradio
 - PARams [kbox[elem]]- get device parameters
 - POLLDevices [0|1] - Poll devices status
 - PCLK [var] - set pclk polarity (0/1)
 - PING [ipaddr] - test TCP/IP ping
 - PLAN [kbox[:elem]] [string|-r] - set/get/remove item test plan name
 - PLED mode - Power LED, 0-off, 1-on, 2-blink,
 - POWER [ena|dis] - power failure logic
 - PRInt index text - send text to server
 - PTemp kbox elem [calVal] - get or calibrate Pic temperature
 - PWD show working directory
 - QUIT - Exit session (Ctrl-C)
 - REAd file offset len - read binary file
 - REBoot - Reboot Netburner request
 - RELay [0|1] - Set relay
 - REProgram kbox old new - Change device bus address
 - RLED mode - RX LED, 0-off, 1-on, 2-dis auto,
 - RMDIR name - remove SD card directory
 - RM name - remove file
 - RNG mode cnt - test RNG
 - RS485 string|hex [hex...] - Send data to RS485 port
 - SD - show SD card statistics
 - SERVAddr [n[addr[:port]]] - Set address (0..3) for status connection
 - SERVNotify [n[opt]] - Enable email notify (0..3) for status connection
 - SERVPort [n[port]] - Set port (0..3) for status connection
 - SESSions - show active telnet sessions
 - SET option [value] - Set/get configuration options
 - SIZE - Get console size
 - SRMReg [kbox [elem [index [val]]]] - set/get SRM register demo value (elem=1 - all)
 - SRMTest [0xEE] 0xBB [kbox] elem reg val [crc] - Send test command to SRM bus
 - SRMBlock loop cnt delay kbox elem reg par - Send test command to multiple elements on SRM bus

-
- STATus - show system status buffer
 - STDIn [0|1] - enable stdin from UART0
 - STDOut [0|1] - enable and send stdout buffer
 - SUPervision [on|off|get [IQRf [addr] | [kbox[elem [elemto]] | load/save csv - show/set/load/save device supervision status
 - SUSpend [0|1] - clear or get suspend flag - MRAM debugging
 - TAIL [val] - set file tail size for cat command
 - TEMp kbox elem | cal val [kb[el]] - get or calibrate temperature
 - TESTReset [kbox [elem]] - reset testa results
 - TEST options - no params to see options
 - TIME - get current system time
 - TLED mode - TX LED, 0-off, 1-on, 2-dis auto,
 - TM cmd [par] - USB-TEST TM command
 - TOUNch [val][sel row col] - add input to the touch buffer
 - TRelay [idx [0|1|2]] - control external test relay (0 for all) (off|on|toggle)
 - TYPE - display SD card file (use 'tail' to limit data)
 - UARTClose n - close UART n
 - UARTL - show UART log
 - UARTOpen n baud - open UART n
 - UARt UART# string - send text to UART n
 - UDPI nit ip remport - init UDP socket
 - UDPStat - send system status to UDP socket
 - UDP string | num [num] - send text or binary data to UDP
 - UPdate [fileName] - update microcode
 - USer [add name pwd|del name] - list, add, remove user name and password
 - VCc kbox elem - get Vcc
 - VERsion - show build version
 - VIRtual [on|off|get [IQRf [addr] | [kbox[elem]]]- show/set device virtual status
 - VOPT [0|1] - control Vopt switch
 - WDT [off|ir|i|r|w|test] - test watchdog timer

10.2 DALI micro controller commands

- 1 - GET_VERSION_HIGH
- 2 - GET_VERSION_LOW
- 3 - SET_INTERFACE_STATE
- 4 - SEND_DALI_SINGLE

5 - SEND_DALI_DOUBLE
13 - SEND_DALI_SINGLE_NO_ANSW
26 - SEND_DALI_2_SINGLE
27 - SEND_DALI_2_DOUBLE
28 - SEND_DALI_2_SINGLE_NO_ANSW
29 - GET_DALI_STATUS

10.3 DALI commands

- 0x00, OFF
- 0x01, UP
- 0x02, DOWN
- 0x03, STEP_UP
- 0x04, STEP_DOWN
- 0x05, RECALL_MAX_LEVEL
- 0x06, RECALL_MIN_LEVEL
- 0x07, STEP_DOWN_AND_OFF
- 0x08, ON_AND_STEP_UP
- 0x09, ENABLE_DACP_SEQUENCE
- 0x10+scene, GO_TO_SCENE
- 0x20, RESET
- 0x21, STORE_ACTUAL_LEVEL_DTR
- 0x2A, STORE_DTR_MAX_LEVEL
- 0x2B, STORE_DTR_MIN_LEVEL
- 0x2C, STORE_DTR_FAILURE_LEVEL
- 0x2D, STORE_DTR_POWER_ON_LEVEL
- 0x2E, STORE_DTR_FADE_TIME
- 0x2F, STORE_DTR_FADE_RATE
- 0x40+scene, STORE_DTR_AS_SCENE
- 0x50+scene, REMOVE_FROM_SCENE
- 0x60+group, ADD_TO_GROUP
- 0x70+group, REMOVE_FROM_GROUP
- 0x80, STORE_DTR_SHORT_ADDRESS
- 0x81, ENABLE_WRITE_MEMORY
- 0x90, QUERY_STATUS
- 0x91, QUERY_CONTROL_GEAR
- 0x92, QUERY_LAMP_FAILURE

-
- 0x93, QUERY_LAMP_POWER_ON
 - 0x94, QUERY_LIMIT_ERROR
 - 0x95, QUERY_RESET_STATE
 - 0x96, QUERY_MISS_SHORT_ADDRESS
 - 0x97, QUERY_VERSION_NUMBER
 - 0x98, QUERY_CONTENT_DTR
 - 0x99, QUERY_DEVICE_TYPE
 - 0x9A, QUERY_PHYS_MINIMUM_LEVEL
 - 0x9B, QUERY_POWER_FAILURE
 - 0x9C, QUERY_CONTENT_DTR_1
 - 0x9D, QUERY_CONTENT_DTR_2
 - 0xA0, QUERY_ACTUAL_LEVEL
 - 0xA1, QUERY_MAX_LEVEL
 - 0xA2, QUERY_MIN_LEVEL
 - 0xA3, QUERY_POWER_ON_LEVEL
 - 0xA4, QUERY_SYSTEM_FAILURE_LEVEL
 - 0xA5, QUERY_FADE_TIME_AND_RATE
 - 0xB0+scene, QUERY_SCENE_LEVEL
 - 0xC0, QUERY_GROUP_0_TO_7
 - 0xC1, QUERY_GROUP_8_TO_15
 - 0xC2, QUERY_RANDOM_ADDRESS_H
 - 0xC3, QUERY_RANDOM_ADDRESS_M
 - 0xC4, QUERY_RANDOM_ADDRESS_L
 - 0xC5, QUERY_READ_MEMORY_LOCATION
 - 0xE0, GO_EMERGENCY_TO_REST_STATE
 - 0xE1, GO_NORMAL_TO_INHIBIT_STATE
 - 0xE2, RESET_INHIBIT_AND_RELIGHT
 - 0xE3, START_FUNCTION_TEST
 - 0xE4, START_DURATION_TEST
 - 0xE5, STOP_TEST
 - 0xE6, RESET_FUNCTION_TEST_DONE
 - 0xE7, RESET_DURATION_TEST_DONE
 - 0xE8, RESET_LAMP_TIME
 - 0xE9, STORE_DTR_EMERGENCY_LEVEL
 - 0xEA, STORE_TEST_DELAY_TIME_H
 - 0xEB, STORE_TEST_DELAY_TIME_L

-
- 0xEC, STORE_FUNC_TEST_INTERVAL
 - 0xED, STORE_DURA_TEST_INTERVAL
 - 0xEE, STORE_TEST_EXEC_TIMEOUT
 - 0xEF, STORE_PROLONG_TIME
 - 0xF0, START_IDENTIFICATION
 - 0xF1, QUERY_BATTERY_CHARGE
 - 0xF2, QUERY_TEST_TIMING
 - 0xF3, QUERY_DURA_TEST_RESULT
 - 0xF4, QUERY_LAMP_EMERGENCY_TIME
 - 0xF5, QUERY_LAMP_TOTAL_OP_TIME
 - 0xF6, QUERY_EMERGENCY_LEVEL
 - 0xF7, QUERY_EMERGENCY_MIN_LEVEL
 - 0xF8, QUERY_EMERGENCY_MAX_LEVEL
 - 0xF9, QUERY_RATED_DURATION
 - 0xFA, QUERY_EMERGENCY_MODE
 - 0xFB, QUERY_FEATURES
 - 0xFC, QUERY_FAILURE_STATUS
 - 0xFD, QUERY_EMERGENCY_STATUS
 - 0xFE, PERFORM_DTR_SELECTED_FUNC
 - 0xFF, QUERY_EXTENDED_VERSION

10.4 DALI extended commands

- 0xA1, TERMINATE
- 0xA3, STORE_TO_DTR
- 0xA5, INITIALISE
- 0xA7, RANDOMISE
- 0xA9, COMPARE
- 0xAB, WITHDRAW
- 0xB1, SEARCH_ADDRESS_H
- 0xB3, SEARCH_ADDRESS_M
- 0xB5, SEARCH_ADDRESS_L
- 0xB7, PROGRAM_SHORT_ADDRESS
- 0xB9, VERIFY_SHORT_ADDRESS
- 0xBB, QUERY_SHORT_ADDRESS
- 0xBD, PHYSICAL_SELECTION
- 0xC1, ENABLE_DEVICE_TYPE

-
- 0xC3, STORE_TO_DTR_1
 - 0xC5, STORE_TO_DTR_2
 - 0xC7, WRITE_MEMORY_LOCATION

11 Size and weight

Weight: 400g. Max ambient temperature: 50°C

